

# FRAMEMASTER BLACK GUN (07-500)

## MAINTENANCE AND TROUBLE SHOOTING

PROBLEM	PROBABLE CAUSE	ACTION
Does not fire point	Out of points	Reload new stack of points
	Point jammed	Remove points and magazine. Remove jammed points and clean magazine
Fires double points	Magazine screw loose	Tighten nut firmly
Point penetration not deep enough	Magazine screw loose	Tighten nut firmly
	Frame not firmly backed up	Use firm backing
	Pressure adjustment loose	Tighten pressure screw

## PARTS LIST

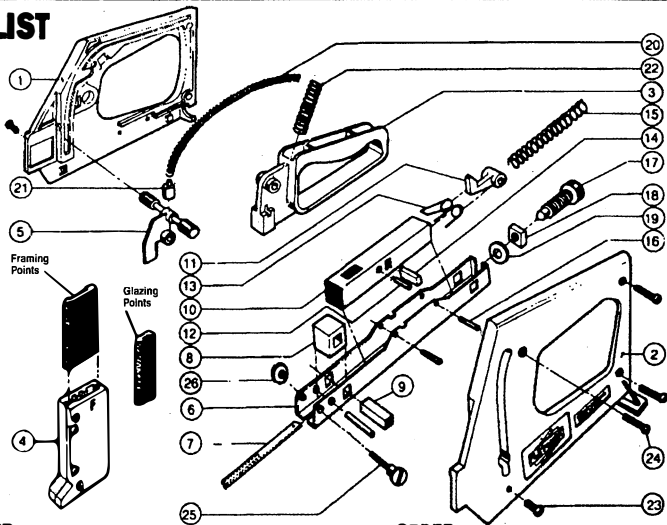

ORDER			ORDER		
ITEM NUMBER	PART NAME	QTY	ITEM NUMBER	PART NAME	QTY
1	12-726	Handle (Rt. Hand)	14	12-713	Spring Stop Plate
2	12-727	Handle (Left Hand)	15	12-714	Main Spring
3	12-702	Trigger Assembly	16	12-715	Guide Pin
4	12-728	Magazine Assembly	17	12-716	Adjusting Knob
5	12-704	Follower Assembly	18	12-717	Square Nut
6	12-729	Channel	19	12-718	Washer
7	12-730	Push Plate	20	12-719	Follower Spring
8	12-707	Bumper	21	12-720	Cap
9	12-708	Stop Bar	22	12-721	Trigger Spring
10	12-709	Hammer	23	12-722	6-32 x 3/8 Screw
11	12-710	Pawl	24	12-723	8-16 x 5/8 Screw
12	12-711	Pawl Pin	25	12-731	Magazine Screw
13	12-712	Dbl Torsion Spring	26	12-725	Magazine Nut



For sales, service and spare parts

[www.apm-mouldings.com.au](http://www.apm-mouldings.com.au)

APM Mouldings 120-130 Bolinda Rd Campbellfield, VIC 3061  
Ph: 03 8301 9199 | Fax 03 9357 4077 | Email [apmoffice@chamton.com](mailto:apmoffice@chamton.com)  
[www.apm-mouldings.com.au](http://www.apm-mouldings.com.au)

Australian Owned Family Company  
Quality Moulding Manufacturers and Distributors



FOR ORDERS  
Available 24/7

